

# WATERFORD SYSTEMS SWIMMING POOL PUMP

O W N E R ' S M A N U A L

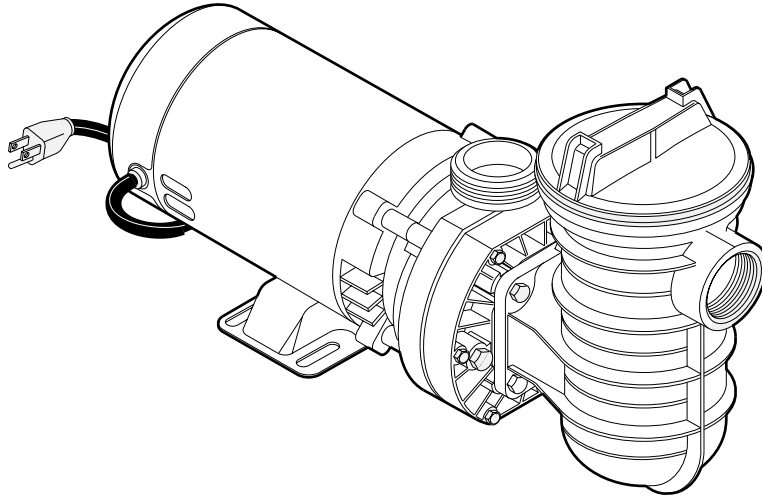

---

## INSTALLATION, OPERATION & PARTS

### MODELS

**1/2 HP**  
JWPA5C

**3/4 HP**  
JWPA5D  
JWPA5DL  
JWPA5DL  
JWPA5D7L

**1 HP**  
JWPA5E  
JWPA5EL  
JWPA5E7  
JWPA5E7L

**1-1/2 HP**  
JWPA5F  
JWPA5FL  
JWPA5F7L

**3/4 HP/2 SPEED**  
JWPXYD  
JWPXYDL

**1 HP/2 SPEED**  
JWPAXYE  
JWPAXYEL  
JWPA5YEL  
JWPA5YE7L  
JWPA5Y7EL

**1-1/2 HP/2 SPEED**  
JWPA5YFL  
JWPA5YF7L

**This manual should be furnished to the end user of this pump; its use will reduce service calls and chance of injury and will lengthen pump life.**

---

### Sta-Rite Pool/Spa Group

293 Wright Street, Delavan, WI 53115

International: 262-728-5551, FAX: 262-728-7550

[www.starite.com](http://www.starite.com)

Union City, TN • Delavan, WI • Mississauga, Ont. • Murrieta, CA

# WATERFORD SYSTEMS SWIMMING POOL PUMP

To avoid unneeded service calls, prevent possible injuries, and get the most out of your pump, READ THIS MANUAL CAREFULLY!

The Sta-Rite 'JWP' Series Above Ground Pool Pump:

- Is designed to circulate water in swimming pools.
- Is an excellent performer; durable, reliable.

## Table of Contents

Safety Instructions .....	2-3
Installation.....	3-5
Electrical .....	5-6
Operation .....	7
Storage/Winterizing .....	8
Pump Service.....	9
Troubleshooting Guide .....	10
Repair Parts List.....	11-12
Warranty.....	16

## IMPORTANT SAFETY INSTRUCTIONS

Always follow basic safety precautions with this equipment, including the following.

**⚠ WARNING** To reduce the risk of injury, do not permit children to use this product unless they are closely supervised at all times.

## SAVE THESE INSTRUCTIONS

## READ AND FOLLOW SAFETY INSTRUCTIONS!

**⚠** This is the safety alert symbol. When you see this symbol on your system or in this manual, look for one of the following signal words and be alert to the potential for personal injury.

**⚠ DANGER** warns about hazards that **will** cause death, serious personal injury, or major property damage if ignored.

**⚠ WARNING** warns about hazards that **can** cause death, serious personal injury, or major property damage if ignored.

**⚠ CAUTION** warns about hazards that **will** or **can** cause minor personal injury or property damage if ignored.

**NOTICE** indicates special instructions not related to hazards.

**Carefully read and follow all safety instructions in this manual and on equipment.** Keep safety labels in good condition; replace if missing or damaged.



**Incorrectly installed or tested equipment may fail, causing severe injury or property damage.**

Read and follow instructions in owner's manual when installing and operating equipment. Have a trained pool professional perform all pressure tests.

1. Do not connect system to a high pressure or city water system.
2. Use equipment only in a pool or spa installation.
3. Trapped air in system can cause explosion. BE SURE all air is out of system before operating or testing equipment.

**Before pressure testing, make the following safety checks:**

Check all clamps, bolts, lids, and system accessories before testing.

Release all air in system before testing.

Tighten Sta-Rite trap lids to 30 ft. lbs. (4.1 kg-m) torque for testing.

Water pressure for test must be less than 25 PSI (7.5 kg/cm<sup>2</sup>).

Water Temperature for test must be less than 100° F. (38° C).

Limit test to 24 hours. After test, visually check system to be sure it is ready for operation. Remove trap lid and retighten hand tight only.

**NOTICE:** These parameters apply to Sta-Rite equipment only. For non-Sta-Rite equipment, consult manufacturer.



Motor normally operates at high temperature and will be too hot to touch. It is protected from heat damage during operation by an automatic internal cutoff switch. Before handling pump or motor, stop motor and allow it to cool for 20 minutes.

## INSTALLATION

**Installation and wiring of pump should only be done by qualified, licensed personnel.**

For self-priming pumps, locate the pump as close as possible to the pool and not more than 3 feet above pool water level.

For ease of pump/motor removal, install pipe unions on the suction and discharge pipes close to pump.

**Pump mount must:**

Be solid - Level - Rigid - Vibration free. (To reduce vibration and pipe stress, bolt pump to mount.)

Allow pump suction inlet height to be at or below water level in pool.

Allow use of short, direct suction pipe (To reduce friction losses).

Allow for gate valves in suction and discharge piping.

Have adequate floor drainage to prevent flooding.

Be protected from excess moisture.

Allow adequate access for servicing pump and piping.

**NOTICE:** Use Teflon tape or Plasto-Joint Stik<sup>1</sup> for making all threaded connections to the pump. Do not use pipe dope; pipe dope will cause stress cracking in the pump.

<sup>1</sup>Lake Chemical Co., Chicago, Illinois

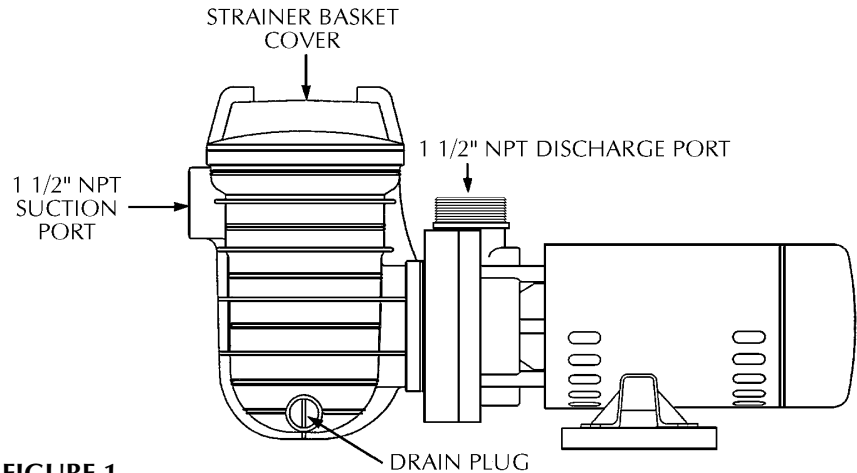

**FIGURE 1**

**NOTICE:** Pump suction and discharge connections have molded in thread stops. DO NOT try to screw pipe in beyond these stops. Tighten the pump/trap fittings only as much as it is required to insure a tight connection (1-1/2 turns past hand tight is sufficient). Overtightening may damage the pump trap. Use care when using teflon tape as friction is reduced considerably; do not overtighten connections or damage may occur.

**Teflon Taping Instructions:**

Use only new or clean PVC pipe fittings.

Wrap male pipe threads with one to two layers of Teflon tape. Cover entire threaded portion of pipe.

**Do not** overtighten or tighten past thread stop in pump port!

If leaks occur, remove pipe, clean off old tape, rewrap with one to two additional layers of tape and remake the connection.

**NOTICE: Support all piping connected with pump!**

**Piping:**

Use at least 1-1/2" (38mm) IPS PVC pipe with 5" (127mm) trap. Increase size if a long run is needed.

To avoid strains on the pump, support both suction and discharge pipes independently. Place these supports near the pump.

To avoid a strain left by a gap at the last connection, start all piping at the pump and run pipe **away** from the pump.

Never use a suction pipe smaller than pump suction connection.

To avoid airlocking, slope suction pipe slightly upward toward the pump.

**NOTICE:** To prevent flooding when removing pump for service, all flooded suction systems **must** have gate valves in suction and discharge pipes.

Plastic pipe will expand and contract as the temperature changes. To allow for this, use an expansion joint or flexible piping.

Union provided for pump discharge port. Use as follows for leak-free connection to pump:

1. O-Ring and sealing surfaces must be clean.
2. Assemble handtight only! (NO WRENCHES!)
3. NO pipe compound or teflon tape on union.
4. Bond pipe to union with PVC cement.

**Use PVC cement only in a well ventilated area away from flame; FOLLOW MANUFACTURER'S INSTRUCTIONS!**

**⚠ WARNING**



**Hazardous voltage. Can shock, burn, or kill.**

- Disconnect power to pump before working on pump or motor.
- Do not alter cord or plug on cord-connected models.
- Connect plug-in models only to a grounded, GFCI protected outlet, that meets code for pool installations.
- Ground hard-wired models before connecting to power supply.

**Fittings:**

Fittings restrict flow; for best efficiency use fewest possible fittings. Avoid fittings which could cause an air trap. Pool fittings must conform to International Association of Plumbing and Mechanical Officials (IAPMO) standards. Use only non-entrapping suction fitting or double suction (skimmer and main drain).

**ELECTRICAL**

- ⚠ **Ground motor before connecting to electrical power supply. Failure to ground motor can cause severe or fatal electrical shock hazard.**
- ⚠ **Do not ground to a gas supply line.**
- ⚠ **To avoid dangerous or fatal electrical shock, turn OFF power to motor before working on electrical connections.**
- ⚠ **Ground Fault Circuit Interrupter (GFCI) tripping indicates an electrical problem. If GFCI trips and will not reset, have a qualified electrician inspect and repair electrical system.**
- ⚠ **Exactly match supply voltage to nameplate voltage! Incorrect voltage can cause fire or seriously damage motor and voids warranty. If in doubt consult a licensed electrician.**

**Voltage:**

Voltage at motor must be not more than 10% above or below motor nameplate rated voltage or motor may overheat, causing overload tripping and reduced component life. If voltage is less than 90% or more than 110% of rated voltage when motor is running at full load, consult power company.

**Grounding/Bonding:**

Install, ground, bond and wire motor according to local or National Electrical Code requirements.

Permanently ground motor; use size and type wire required by code. Ground connection must be made to green grounding terminal under motor canopy or access plate (see Figure 2A).

Connect motor ground terminal to electrical service ground.

Install and bond pump according to local codes and ordinances; use bonding lug on motor (see Figure 2A). Use solid copper conductor No. 8 AWG (8.4 sq. mm) or larger.

Connect a No. 8 AWG (8.4 sq. mm) solid copper bonding wire to the pressure wire connector provided on the motor housing and to all metal parts of the swimming pool, spa, or hot tub and to all electrical equipment, metal piping or conduit within 5 feet (1.5m) of the inside walls of the swimming pool, spa or hot tub.

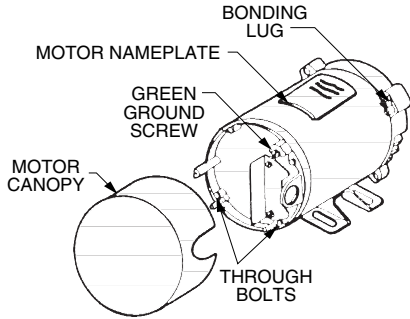

**A: Typical ground screw and bonding lug locations.**

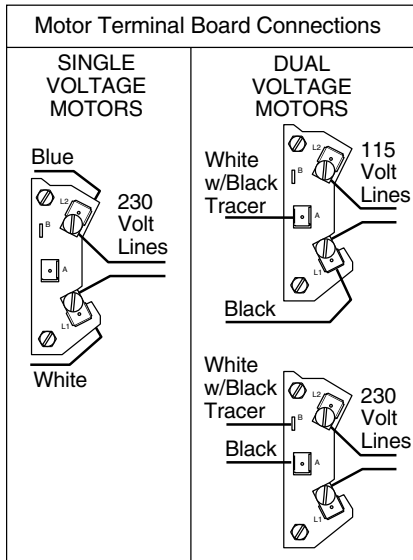

**B. Motor terminal block connections.**

**Figure 2 – Electrical connections for single speed models; motor terminal block and bonding.**

**Wiring:**

Do not alter cord or plug on cord-connected units. Plug in to a GFCI protected, grounded outlet only. If plug and outlet do not match, consult a licensed electrician.

Pump must be permanently connected to circuit. Table I, Page 5, gives correct wire and circuit breaker sizes for the pump alone. If other lights or appliances are also on the same circuit, be sure to add their amp loads to pump amp load before figuring wire and circuit breaker sizes. (If unsure how to do this or if this is confusing, consult a licensed electrician.) Use the load circuit breaker as the master on-off switch.

Install a Ground Fault Circuit Interrupter (GFCI) in circuit; it will sense a short-circuit to ground and disconnect power before it becomes dangerous to pool users. For size of GFCI required and test procedures for GFCI, see manufacturer’s instruction.

In case of power outage, check GFCI for tripping (which will prevent normal pump operation). Reset if necessary.

**NOTICE:** If you do not use conduit when wiring motor, **be sure** to seal wire opening on end of motor to prevent dirt, bugs, etc., from entering.

**Remote Switching For 2-Speed Pumps**

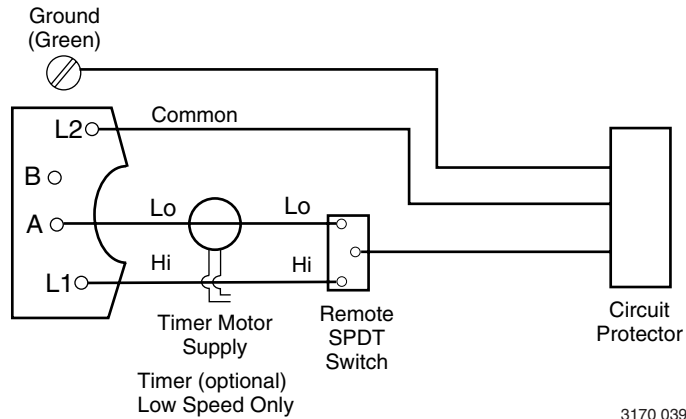

3170 0398

Minimum switch and timer amp rating must equal Branch Fuse Rating given in "Recommended Circuit Breaker Size and Wiring Data" table.



**⚠ Values given in table below are for PUMP MOTOR ONLY. If additional accessories are installed on pump motor circuit (heater, blower, etc.), include their amperage draw when figuring wire and circuit breaker sizes.**

**TABLE I - RECOMMENDED FUSING AND WIRING DATA**

Model Number	Motor H.P.	Branch Fuse Rating Amps*	Max Load Amps	Voltage/Hz/Phase	Dist. in Ft. (m) (Serv. to Motor)			Temp. Rating-°C
					0-100' (0-30)	101-200' (31-60)	201-300' (61-90)	
<b>1-Speed</b>								
JWPA5C-2A8	1/2	15	9.0	115/60/1	14 (2)	12 (3)	10 (5.5)	75
JWPA5DL-2A	3/4	15	9.0	115/60/1	14 (2)	12 (3)	10 (5.5)	75
JWPA5DL-2A1	3/4	15	9.0	115/60/1	14 (2)	12 (3)	10 (5.5)	75
JWPA5DL-2A2	3/4	15	9.0	115/60/1	14 (2)	12 (3)	10 (5.5)	75
JWPA5D-2A	3/4	15	9.0	115/60/1	14 (2)	12 (3)	10 (5.5)	75
JWPA5D-2A4	3/4	15	9.0	115/60/1	14 (2)	12 (3)	10 (5.5)	75
JWPA5D-2A8	3/4	15	9.0	115/60/1	14 (2)	12 (3)	10 (5.5)	75
JWPA5D7L-2A	3/4	15	9.0	115/60/1	14 (2)	12 (3)	10 (5.5)	75
JWPA5D7L-2A1	3/4	15	9.0	115/60/1	14 (2)	12 (3)	10 (5.5)	75
JWPA5D7L-2A2	3/4	15	9.0	115/60/1	14 (2)	12 (3)	10 (5.5)	75
JWPA5EL-2A	1	15	12.0	115/60/1	14 (2)	10 (5.5)	8 (8.4)	75
JWPA5EL-2A1	1	15	12.0	115/60/1	14 (2)	10 (5.5)	8 (8.4)	75
JWPA5EL-2A2	1	15	12.0	115/60/1	14 (2)	10 (5.5)	8 (8.4)	75
JWPA5E7-2A4	1	15	12.0	115/60/1	14 (2)	10 (5.5)	8 (8.4)	75
JWPA5E7L-2A	1	15	12.0	115/60/1	14 (2)	10 (5.5)	8 (8.4)	75
JWPA5E7L-2A1	1	15	12.0	115/60/1	14 (2)	10 (5.5)	8 (8.4)	75
JWPA5E7L-2A2	1	15	12.0	115/60/1	14 (2)	10 (5.5)	8 (8.4)	75
JWPA5F-2A	1½	20	16	115/60/1	10 (5.5)	8 (8.4)	6 (14)	75
JWPA5FL-2A	1½	20	16	115/60/1	10 (5.5)	8 (8.4)	6 (14)	75
JWPA5FL-2A1	1½	20	16	115/60/1	10 (5.5)	8 (8.4)	6 (14)	75
JWPA5FL-2A2	1½	20	16	115/60/1	10 (5.5)	8 (8.4)	6 (14)	75
JWPA5FL-A	1½	25/15	16.4/8.2	115/230/60/1	10/14 (5.5/2)	8/14 (8.4/2)	6/12 (14/3)	75
JWPA5F7L-2A4	1½	20	16	115/60/1	10 (5.5)	8 (8.4)	6 (14)	75
JWPA5D-230A	3/4	15	4.8	230/60/1	14 (2)	14 (2)	14 (2)	75
JWPA5E-230A	1	15	6.1	230/60/1	14 (2)	14 (2)	14 (2)	75
JWPA5E-230A2	1	15	6.1	230/60/1	14 (2)	14 (2)	14 (2)	75
<b>2-Speed</b>								
JWPXYD-A2	3/4 – 1/8	15	11.7/3.39	115/60/1	14 (2)	10 (5.5)	8 (8.4)	75
JWPXYDL-A2	3/4 – 1/8	15	11.7/3.39	115/60/1	14 (2)	10 (5.5)	8 (8.4)	75
JWPAXYE-A2	1 – 1/8	15	11.7/3.39	115/60/1	14 (2)	10 (5.5)	8 (8.4)	75
JWPA5YEL-A1	1 – 1/8	15	11.7/3.39	115/60/1	14 (2)	10 (5.5)	8 (8.4)	75
JWPA5YEL-A2	1 – 1/8	15	11.7/3.39	115/60/1	14 (2)	10 (5.5)	8 (8.4)	75
JWPA5YE7L-A1	1 – 1/8	15	11.7/3.39	115/60/1	14 (2)	10 (5.5)	8 (8.4)	75
JWPA5YE7L-A2	1 – 1/8	15	11.7/3.39	115/60/1	14 (2)	10 (5.5)	8 (8.4)	75
JWPA5YFL-A	1½ – 1/6	20	16.0/3.6	115/60/1	12 (3)	8 (8.4)	6 (14)	75
JWPA5YFL-A2	1½ – 1/6	20	16.0/3.6	115/60/1	12 (3)	8 (8.4)	6 (14)	75
JWPA5YF7L-A1	1½ – 1/6	20	16.0/3.6	115/60/1	12 (3)	8 (8.4)	6 (14)	75
JWPA5YF7L-A2	1½ – 1/6	20	16.0/3.6	115/60/1	12 (3)	8 (8.4)	6 (14)	75

Wire Size AWG (mm)

\*Time delay fuses are recommended instead of standard fuses in any motor circuit.



## OPERATION

**⚠ NEVER run pump dry! Running pump dry may damage seals, causing leakage and flooding! Fill pump with water before starting motor.**

**⚠ Before removing trap cover:**

1. **STOP PUMP** before proceeding.
2. **CLOSE GATE VALVES** in suction and discharge pipes.
3. **RELEASE ALL PRESSURE** from pump and piping system.
4. **NEVER tighten or loosen clamp while pump is operating!**

**⚠ If pump is being pressure tested, be sure pressure has been released before removing trap cover!**

**⚠ Do not block pump suction! To do so with body may cause severe or fatal injury. Small children using pool must ALWAYS have close adult supervision!**

**NOTICE:** Do not block pool return or spa jets. To do so may flood area causing damage to equipment and water damage to surrounding area.

### Priming Pump:

Open gate valves before starting system.

Release all air from filter and piping system: see filter owner's manual.

In a flooded suction system (water source higher than pump), pump will prime itself when suction and discharge valves are opened.

If pump is not in a flooded suction system, unscrew and remove trap cover; fill trap and pump with water.

Do not lubricate the trap cover O-Ring. The original equipment O-Ring contains a permanent internal lubricant.

**NOTICE:** If you replace the O-Ring with a non-internally lubricated O-Ring, you may need to apply a silicone based lubricant.

Clean and inspect O-Ring; reinstall on trap cover.

Replace trap cover on trap; turn clockwise to tighten cover.

**NOTICE:** Tighten trap cover by hand only (**no wrenches**)! Use a wrench only if necessary to remove lid.

Pump should prime now. Priming time will depend on vertical length of suction lift and horizontal length of suction piping.

If pump does not prime within 10 minutes, stop motor and find cause. Make sure that all valves are open, suction pipe end is under water, and that there are no leaks in suction pipe.

See Troubleshooting Guide, Page 11.

### Pool, Spa or Tub Water:

Keep water level at least two inches above bottom of skimmer opening when system is not in use. Failure to do so can allow air to enter system, causing pump to lose its prime.

Keep water temperature at 104°F or below for spas/tubs and 80°F for pools. If in doubt, start at a lower temperature and gradually increase it according to your experience.

Keep an accurate thermometer in pool/spa; check it before getting in.

Keep pool water "balanced". Maintain the water pH between 7.2 and 7.6.

**⚠ Do not use or allow the use of the spa/pool by anyone using alcohol or drugs. The effects of hot water, alcohol and/or drugs can cause dizziness and falling, loss of consciousness, or heart attack.**

## Storage/Winterizing:

**⚠ WARNING** Explosion hazard. Purging the system with compressed air can cause components to explode, with risk of severe injury or death to anyone nearby. Use only a low pressure (below 5 PSI), high volume blower when air purging the pump, filter, or piping.

**⚠** To prevent damage to components from fumes, store spa chemicals away from pump and spa. If possible, store chemicals in another room.

**NOTICE:** Allowing pump to freeze will damage pump and void warranty!

**NOTICE: Do not** use anti-freeze solutions (except propylene glycol) in your pool/spa system. Propylene glycol is non-toxic and will not damage plastic system components; other anti-freezes are highly toxic and may damage plastic components in the system. Propylene glycol is widely used as antifreeze in recreational vehicles.

Drain all water from pump and piping when expecting freezing temperatures or when storing pump for a long time (see instructions below).

Keep motor dry and covered during storage.

To avoid condensation/corrosion problems, **do not** cover or wrap pump with plastic.

For outdoor/unprotected installations:

1. Pump down water level below all inlets to pool.
2. Enclose entire system in a weatherproof enclosure.
3. To avoid condensation/corrosion damage, allow ventilation; **do not** wrap system in plastic.
4. Use a 40% propylene glycol/60% water solution to protect pump to -50°F.
5. Follow pool manufacturer's directions for storage of pool.



## Draining Pump:

**⚠ WARNING** To avoid dangerous or fatal electrical shock hazard, turn OFF power to motor before draining pump.

1. Close all valves on suction and return piping.
2. Remove drain plug in bottom of volute.
3. Drain all piping and storage tanks exposed to freezing temperatures.
4. Be sure no airlocks are holding water in the system.
5. To prevent pump from freezing, remove trap cover and drain the tank body through the drain plug (Key No. 14, Page 12). Use a lid wrench to remove trap covers that have been overtightened or have taken a set and cannot be removed by hand. Clean pump thoroughly. Replace trap cover.
6. Before restarting, replace all plugs and make sure all pipe connections are tightly sealed.

## Startup For Winterized Equipment:

1. Remove any temporary weather protection placed around system for shutdown.
2. Follow filter manufacturer's instructions for reactivation of the filter.
3. Inspect all electrical wiring for damage or deterioration over the shutdown period. Have a qualified serviceman repair wiring as needed.
4. Inspect and tighten all watertight connections.
5. Open all valves in suction and return piping.
6. Remove any winterizing plugs in piping system.
7. Drain all antifreeze from system.
8. Close all drain valves and replace all drain plugs in piping system.
9. Prime pump according to instructions on Page 7.
10. Refill pool to proper water level.

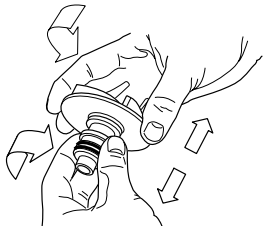

Figure 3

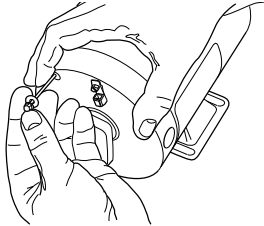

Figure 4

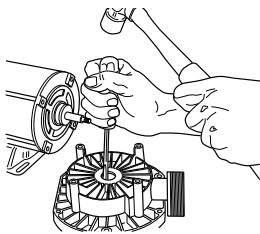

Figure 5

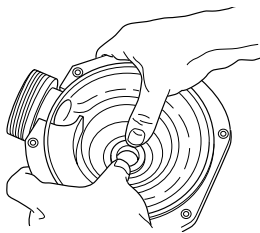

Figure 6

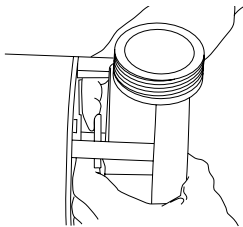

Figure 7

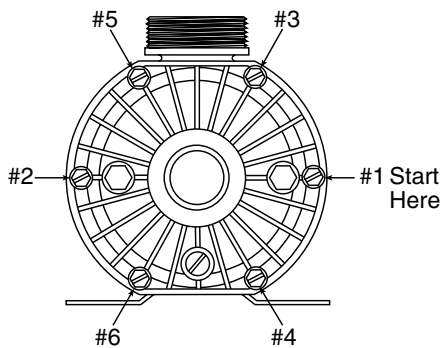

Figure 8 – Torque Sequence

## PUMP SERVICE

Pump should only be serviced by qualified personnel.  
For best results, use only genuine Sta-Rite factory parts.

Be sure to prime pump (Page 7) before restarting.

**⚠** Before removing trap cover:

1. STOP PUMP before proceeding.
2. CLOSE GATE VALVES in suction and discharge pipes.
3. RELEASE ALL PRESSURE from pump and piping system.
4. NEVER tighten or loosen clamp while pump is operating!

**⚠ WARNING** To avoid dangerous or fatal electrical shock hazard, turn OFF power to motor before working on pump or motor.

Aside from lubricating trap cover O-Ring, no lubrication or regular maintenance is needed beyond reasonable care and periodic cleaning.

If shaft seal is worn or damaged, repair as follows:

### Removing Old Seal:

1. Disconnect power to pump motor.
2. Drain tub and pump; disconnect unions to allow access to pump.
3. Remove six bolts holding front plate to seal plate; remove front plate.
4. Remove shaft cover or motor canopy; using screwdriver in slot on motor end of shaft or wrench on flats of shaft extension, hold pump shaft and unscrew impeller from shaft (turn counterclockwise). Rotating half of seal will come off with impeller.
5. Carefully remove rotating part of seal from impeller sleeve by pulling and turning on sealing washer and spring (Figure 3). Do not damage impeller surface where drive ring seats and seals.
6. Carefully remove four motor throughbolts from seal plate (Figure 4); remove seal plate and use a screwdriver to tap ceramic seat out from the rear (Figure 5). Do not damage seal cavity in seal plate.
7. Clean cavity from which seal was removed and clean motor shaft.

### Installing New Seal:

1. Ceramic seat must be clean and free of dirt, grease, dust, etc. Wet rubber cup gasket of ceramic seat with **small** amount of water; press into cavity firmly and squarely with finger pressure (Figure 6).
2. If ceramic seat will not locate properly, remove it, place **face up** on bench, and reclean cavity. Ceramic seat should now locate.
3. Seal must be free of dirt, grease, grit, scratches or chips; be sure impeller sleeve is clean. Slide seal assembly, rubber drive ring first, onto impeller sleeve until drive ring bottoms on impeller back shroud.
4. Slip slinger over shaft; remount seal plate. Torque throughbolts to 25 inch-lbs. (29 cm-kg).
5. Screw impeller onto shaft until it seats against shaft shoulder. Work slinger over end of impeller sleeve so it rides on sleeve (Figure 7).
6. Install Wear Ring on back of Front Plate. **NOTICE:** Teeth on Wear Ring interlock with ribs in Front Plate.
7. Remount front plate; using pattern, shown in Figure 8, torque bolts to 30 inch-lbs. (34.5 cm-kg). **BE SURE** to start with bolt in 3 o'clock position as shown.
8. Reconnect unions; tighten **hand tight only**.

# TROUBLESHOOTING GUIDE

**⚠ Read and understand safety and operating instructions in this manual before doing any work on pump!**

**⚠ Only qualified personnel should electrically test pump motor!**

## **FAILURE TO PUMP; REDUCED CAPACITY OR DISCHARGE PRESSURE**

### **Suction leaks/lost prime:**

1. Pump must be primed; make sure that pump volute and trap are full of water. See priming instructions, Page 7.
2. Make sure there are no leaks in suction piping.
3. Make sure suction pipe inlet is well below the water level to prevent pump from sucking air.
4. If suction trap gasket is defective, replace it.
5. Suction lift of 3 to 4 feet (.9-1.2M) will reduce performance. Suction lift of more than 4 feet (1.2M) will prevent pumping and cause pump to lose prime. In either case, move pump closer (vertically) to water source. Make sure suction pipe is large enough.

### **Clogged pipe/trap/impeller, worn impeller:**

1. Make sure suction trap is not clogged; if it is, clean trap and strainer.
2. Make sure impeller is not clogged (follow instructions under "Removing Old Seal", Page 9; check impeller for clogging; follow instructions under "Installing New Seal", above, for reassembly).
3. Impeller and diffuser may be worn. If so, order replacement parts from Repair Parts List, Page 11.

### **Inadequate Circulation or Jet Action:**

1. Check for blocked fittings. Blocked fittings will cause poor flow and poor jet action.
2. Check trap basket; if plugged, turn pump off and clean basket. Check and clean skimmer basket.
3. Check that gate valves are fully open.
4. Suction/discharge piping is too small.
5. Check and clean pool filter.
6. Check for clogged pipe/trap/impeller, Page 9.
7. Consult dealer/installer or service representative.

### **Circuit Breaker In Home Panel Trips Repeatedly:**

1. Breaker must be of adequate capacity.
2. For GFCI breaker, test according to GFCI manufacturer's instructions.
3. Be sure no other lights and appliances are on circuit.
4. Consult dealer/installer or service representative.
5. Voltage too high or too low. See "Voltage", Page 6.

### **Electrical:**

1. Pump may be running too slowly; check voltage at motor terminals and at meter while pump is running. If low, see wiring instructions or consult power company. Check for loose connections.
2. Pump may be too hot.
  - A. Check line voltage; if less than 90% or more than 110% of rated voltage consult a licensed electrician.
  - B. Increase ventilation.
  - C. Reduce ambient temperature.
  - D. Tighten any loose wiring connections.
3. Motor internal thermal overload protector is open. Motor runs too hot. Turn power to motor off. Check for proper voltage. Check for proper impeller or impeller rubbing.
4. Consult dealer/installer or service representative.

### **Mechanical Troubles and Noise:**

1. If suction and discharge piping are not adequately supported, pump assembly will be strained. See "Installation", Page 4.
2. Do not mount pump on a wooden platform! Securely mount on concrete platform for quietest performance.
3. Air leak in suction line (bubbles in water returning to pool). Repair leak. Tighten trap lid.
4. Foreign matter (gravel, metal, etc.) in pump impeller. Disassemble pump, clean impeller, follow pump service instructions on Page 9 for reassembly.
5. Cavitation.
  - Improve suction conditions.
  - Increase pipe size.
  - Decrease number of fittings.
  - Increase discharge pressure.
  - Reducer flow by throttling discharge gate valve.

# REPAIR PARTS LIST

## 1/2 and 3/4 HP

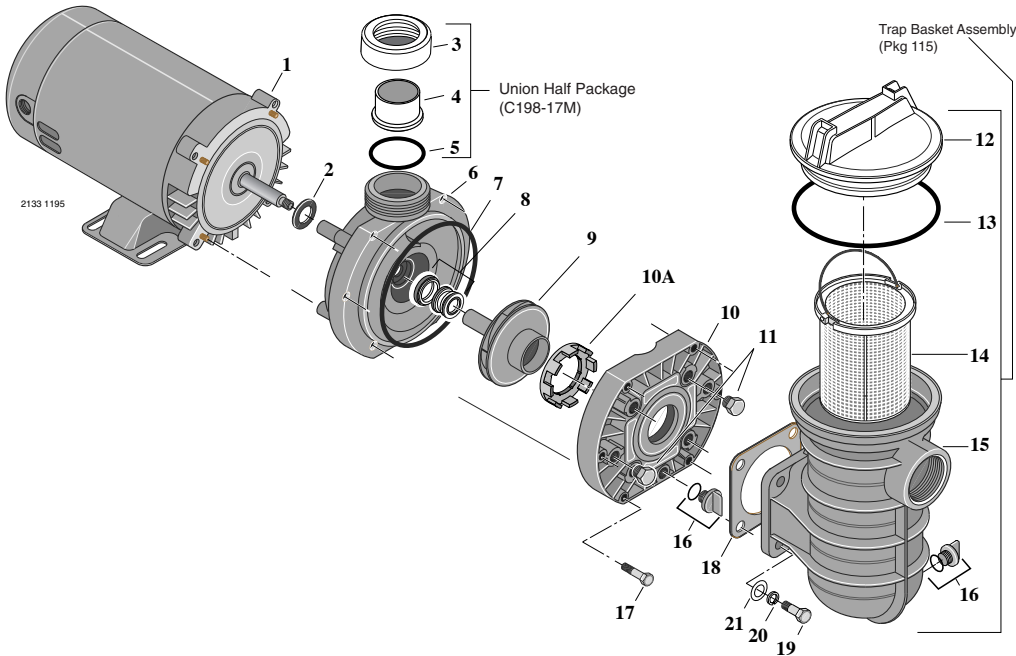

Key No.	Description	Qty.	JWPA5C-2A8 1/2 HP	JWPA5D-2A, -230A JWPA5D-2A4, -2A8 JWPA5DL-2A JWPA5DL-2A1, -2A2 JWPA5D7L-2A JWPA5D7L- 2A1, -2A2 JWPXYD-A2 (2-Speed)* JWPXYDL-A2 (2-Speed)* 3/4 HP
1	Motor 115V/60H/1 Ph.	1	AS920CLL	AS920DLL
1	Motor, 115V, 2-Speed		-	62003-2021
1	Motor, 230V		-	AS923DL
2	Water Slinger	1	C69-2	C69-2
3	Collar, Union (+)	2	-	U11-182P1
4	Adapter, Union (+)	2	-	U11-201P1
5	O-Ring (+)	2	-	U9-226
6	Seal Plate	1	17301-0150	17301-0150
7	O-Ring	1	U9-357	U9-357
8	Shaft Seal	1	U109-358SS	U109-358SS
9	Impeller	1	C105-228PJ	C105-228PH
10	Front Plate Assembly (Includes Key No. 10A)	1	C101-272PS	C101-272PS
10A	Wear Ring**	1		
11	Drain Plug, 1/4", taped	2	WC78-40T	WC78-40T
12	Trap Cover, W/ O-Ring	1	C103-139P1	C103-139P1
12	Trap Cover (Biguanide Resistant)	1	C103-139P3	C103-139P3
13	O-Ring, Trap Cover	1	U9-229	U9-229
14	Strainer Basket	1	C108-33P	C108-33P
15	Trap Body	1	C53-23P1	C53-23P1
16	Pipe Plug, 1/4" NPT (with O-Ring)	2	U178-920P	U178-920P
17	Bolt, Hx Head, 1/4-20 x 1-3/4"	6	30387-0005	30387-0005
18	Gasket, Suction	1	C20-123	C20-123
19	Capscrew, 5/16-18x1-1/4"	4	U30-64SS	U30-64SS
20	Lockwasher, 5/16"	4	U43-11SS	U43-11SS
21	Washer, 5/16" Flat	4	U43-41SS	U43-41SS
	• Cord Assembly, Straight Plug (-A2, -2A2)	1	-	U117-1117
	• Cord Assembly, Twist-Lok Plug (-2A1)	1	-	31953-0101
	• Cord Assembly, 6' Non-UL (-2A4)	1	-	31953-0116
	• Cord Assembly, (-2A8)	1	31953-0019	31953-0019

• Not Illustrated.

\* Models JWPXYD-A2 and JWPXYDL-A2 do not include Suction Trap Assembly.

\*\* Not available separately.

(+) Union Half Package is included with Models: JWPAXYE-A2, JWPAXYEL-A2, JWPA5D-230A, JWPA5DL-2A, JWPXYD-A2, JWPXYDL-A2, JWPA5E-230A, JWPA5E-230A, JWPA5EL-2A, AND JWPA5FL-2A ONLY.

Model Numbers that have a number "7" in them, for example JWP5YE7L-A2 come with the seal plate discharge port in a horizontal position. Part Numbers without the number "7" in them, for example JWP5YEL-A2 come with the seal plate discharge port in a vertical position.

Model Numbers ending in "-230A" and "-2A" do not come with a cord. Model Numbers including the letter "Y" are 2-speed. Order PKG 115 for a complete suction trap assembly.

# REPAIR PARTS LIST

## 1 and 1-1/2 HP

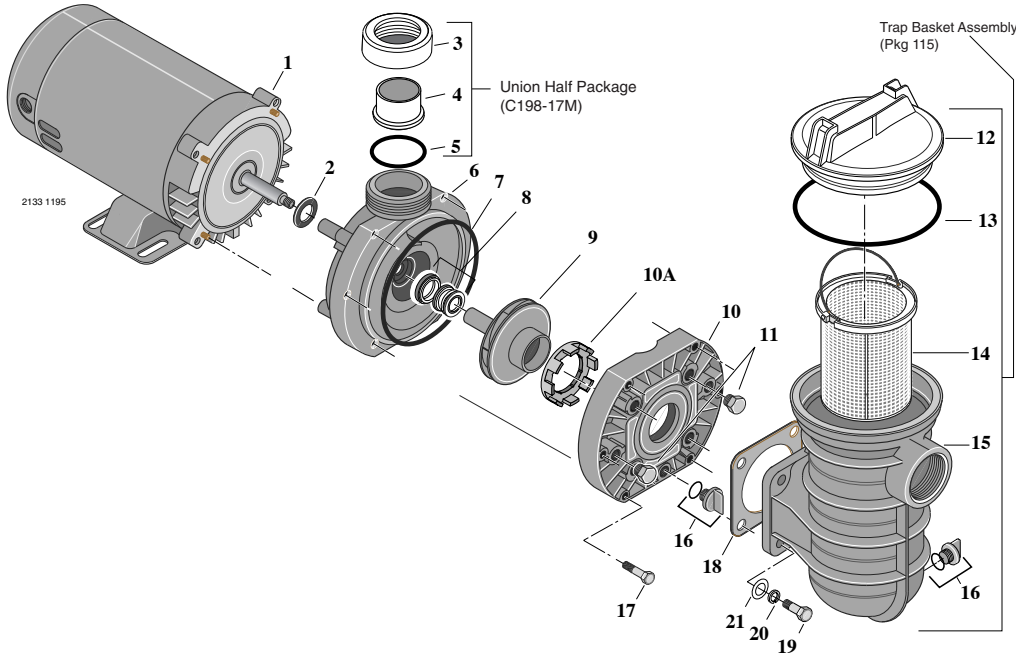

Key No.	Description	Qty.	JWPAXYE-A2* JWPAXYEL-A2* 1 HP/ 2 Speed	JWPA5E-2A, -2A4 JWPA5E-230A, 230A2 JWPA5EL-2A JWPA5EL-2A1, -2A2 JWPA5E7-2A4 JWPA5E7L-2A JWPA5E7L-2A1, -2A2 JWPA5YEL-A, -A1, -A2 JWPA5YE7L-A1, -A2 1 HP	JWPA5F-2A JWPA5FL-A, -2A JWPA5FL-2A1, -2A2 JWPA5F7L-2A4, -2A1 JWPA5YFL-A, -A2 JWPA5YF7L-A1, -A2 1-1/2
1	Motor 115V/60H/1 Ph.	1	-	AS920ELL	AS920FLL
1	Motor, 115V, 2-Speed		62003-2021	62003-2021	62003-2032
1	Motor, 230V		-	AS923EL	-
2	Water Slinger	1	C69-2	C69-2	C69-2
3	Collar, Union (+)	2	U11-182P1	U11-182P1	U11-182P1
4	Adapter, Union (+)	2	U11-201P1	U11-201P1	U11-201P1
5	O-Ring (+)	2	U9-226	U9-226	U9-226
6	Seal Plate	1	17301-0150	17301-0150	17301-0150
7	O-Ring	1	U9-357	U9-357	U9-357
8	Shaft Seal	1	U109-358SS	U109-358SS	U109-358SS
9	Impeller	1	C105-228PG	C105-228PG	C105-228PG
10	Front Plate Assembly (Includes Key No. 10A)	1	C101-272PS	C101-272PS	C101-272PS
10A	Wear Ring**	1	-	-	-
11	Drain Plug, 1/4", taped	2	WC78-40T	WC78-40T	WC78-40T
12	Trap Cover, W/ O-Ring	1	-	C103-139P1	C103-139P1
12	Trap Cover (Biguanide Resistant)	1	-	C103-139P3	C103-139P3
13	O-Ring, Trap Cover	1	-	U9-229	U9-229
14	Strainer Basket	1	-	C108-33P	C108-33P
15	Trap Body	1	-	C53-23P1	C53-23P1
16	Pipe Plug, 1/4" NPT (with O-Ring)	2	-	U178-920P	U178-920P
17	Bolt, Hx Head, 1/4-20 x 1-3/4"	6	30387-0005	30387-0005	30387-0005
18	Gasket, Suction	1	-	C20-123	C20-123
19	Capscrew, 5/16-18x1-1/4"	4	-	U30-64SS	U30-64SS
20	Lockwasher, 5/16"	4	-	U43-11SS	U43-11SS
21	Washer, 5/16" Flat	4	-	U43-41SS	U43-41SS
•	Cord Assembly, Straight Plug (-A2,-230A2, -2A2)	1	U117-1117	U117-1117	U117-1117
•	Cord Assembly, Twist-Lok Plug (-A1, -2A1)	1	-	31953-0101	31953-0101
•	Cord Assembly, 6' Non-UL (-2A4)	1	-	31953-0116	31953-0116

• Not Illustrated.

\* Models JWPAXYE-A2 and JWPAXYEL-A2 do not include Suction Trap Assembly.

\*\* Not available separately.

(+) Union Half Package is included with Models: JWPAXYE-A2, JWPAXYEL-A2, JWPA5D-230A, JWPA5DL-2A, JWPXYD-A2, JWPXYDL-A2, JWPA5E-230A, JWPA5E-230A, JWPA5EL-2A, AND JWPA5FL-2A ONLY.

Model Numbers that have a number "7" in them, for example JWP5YE7L-A2 come with the seal plate discharge port in a horizontal position. Part Numbers without the number "7" in them, for example JWP5YEL-A2 come with the seal plate discharge port in a vertical position.

Model Numbers ending in "-230A", "-2A", or "-A" do not come with a cord. Model Numbers including the letter "Y" are 2-speed.

Order PKG 115 for a complete suction trap assembly.





## STA-RITE LIMITED WARRANTY

Pumps, filters, skimmers, underwater lights (except bulbs), accessories and fittings manufactured by Sta-Rite are warranted to be free of defects in material and workmanship for one (1) year from date of installation.

**Product specific warranties:** **Year from date of installation**

<i>HRPB, DEPB, System 3, System 2 and Posi-Clear</i>	
Tanks .....	10 years
Internal filter components and valves .....	1 year
<i>Max-E-Therm - Pool/Spa Heaters</i> .....	
Heater Enclosure only (Upper RH & LH; lower enclosure; and control board enclosure)...	10 years
<i>Automatic Pool Cleaners including Hose</i> .....	
	2 years
<i>Cristal-Flo filters - Tanks</i> .....	
Valve and internal components. ....	1 year
<i>Posi-Flo II - Tanks</i> .....	
Elements .....	1 year
<i>PRC Cartridge -</i>	
Filter Tanks .....	5 years pro-rated (1st 2 years full)
Elements .....	1 year
<i>System 2 Above Ground Systems - Tanks</i> .....	
Pumps / Platform and Internals .....	1 year
<i>Pumps</i> .....	
When equipped with A.O. Smith 2-compartment motors (Does not include pumps sold as part of a systems package) .....	2 years
<i>Traps / In-Line Strainers</i> .....	
	1 year
<i>Vertical Commercial Filter - Tanks</i> .....	
Internals .....	1 year
<i>Horizontal Commercial Filter</i>	
Tanks .....	5 years
(Years 6-9, Prorated declining 20%/year, Yr. 10 - 10%)	
Internals .....	1 year

\* Full warranty coverage is in effect for one year after installation. The pro-rated warranty covers the *tank only* during the 2nd through 10th year after installation. The amount covered decreases by 10% each year. (ie., 2nd year 90% covered, 3rd year 80% covered, etc.).

The foregoing warranties relate to the original consumer purchaser ("Purchaser") only. Sta-Rite shall have the option to repair or replace the defective product, at its sole discretion. Purchasers must pay all labor and shipping charges necessary to replace the product covered by this warranty. Requests for warranty service must be made through the installing dealer. This warranty shall not apply to any product that has been subject to negligence, misapplication, improper installation or maintenance, or other circumstances which are not in Sta-Rite's direct control.

This warranty sets forth Sta-Rite's sole obligation and Purchaser's exclusive remedy for defective products.

STA-RITE SHALL NOT BE LIABLE FOR ANY CONSEQUENTIAL, INCIDENTAL OR CONTINGENT DAMAGES WHATSOEVER.

THE FOREGOING WARRANTIES ARE EXCLUSIVE AND IN LIEU OF ALL OTHER EXPRESS WARRANTIES. IMPLIED WARRANTIES, INCLUDING BUT NOT LIMITED TO THE IMPLIED WARRANTIES OF MERCHANTABILITY AND FITNESS FOR A PARTICULAR PURPOSE, SHALL NOT EXTEND BEYOND THE DURATION OF THE APPLICABLE EXPRESS WARRANTIES PROVIDED HEREIN.

Some states do not allow the exclusion or limitation of incidental or consequential damages or limitations on how long an implied warranty lasts, so the above limitations or exclusion may not apply to you. This warranty gives you specific legal rights and you may also have other rights which vary from state to state.

Supersedes all previous publications.

**Sta-Rite Industries**  
293 Wright St., Delavan, WI 53115

▲ Retain Warranty Certificate (upper portion) in a safe and convenient location for your records.

DETACH HERE: Fill out bottom portion completely and mail within 10 days of purchase/installation to:

▼ Sta-Rite, Attn: Warranty Dept., 293 Wright St., Delavan, WI 53115



## Warranty Registration Card

Name \_\_\_\_\_

Years pool has been in service  less than 1  1-3  3-5  5-10

Address \_\_\_\_\_

Purchased from:  
Company name \_\_\_\_\_

City \_\_\_\_\_ State \_\_\_\_\_ Zip \_\_\_\_\_

Address \_\_\_\_\_

Purchase Date \_\_\_\_\_

City \_\_\_\_\_ State \_\_\_\_\_ Zip \_\_\_\_\_

Product Purchased \_\_\_\_\_

New installation  Replacement

Please send me more information on these other products from Sta-Rite.

Type of Pool  Inground  Vinyl  Fiberglass  Gunite

- Pumps  Filters  Automatic Pool Cleaners
- Maintenance Equipment  Test Strips
- Heaters

Size of Pool \_\_\_\_\_